

SINCE 1992

# NUETECH

ENERGY FOR CHANGING WORLD



FOLLOW US ON



## Introducing **NUETECH GLASS LINE** SOLAR WATER HEATER

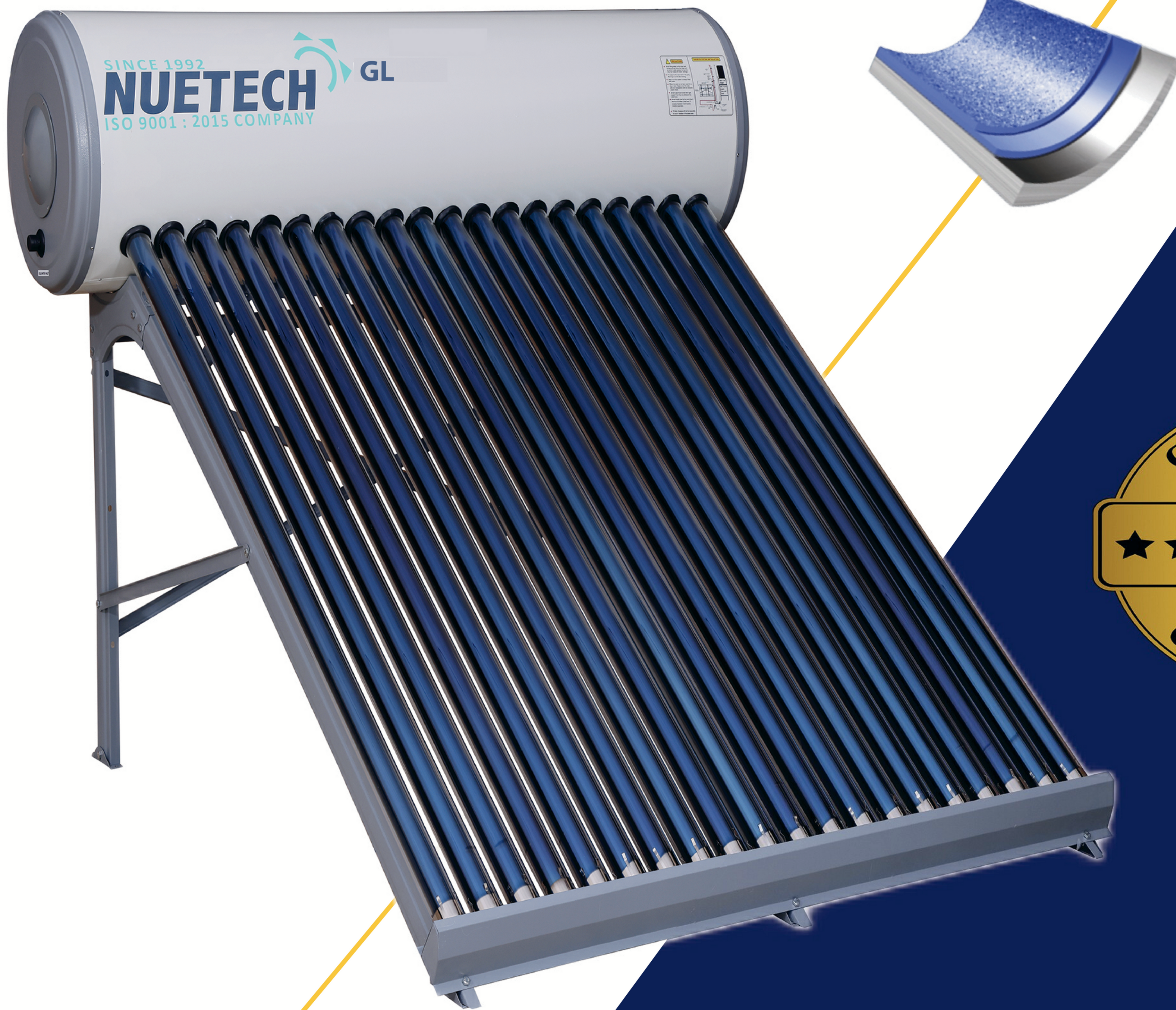

WITH  
GLASS LINE  
TECHNOLOGY



IS 16544:2016



CM/L-6200192943

### WHAT IS GLASS LINE TECHNOLOGY?

Glass Lining is an adhesive coating made by fusing powdered glass to the inner surface of metal tank by baking between 850 C to 870 C. The Glass lining provides excellent and durable protection against rust and corrosion ensuring a longer lifespan for the Solar Water heater

Since 1992, Nuetech Solar Systems Pvt Ltd has been an experienced frontrunner in the supply and manufacture of solar water heaters. We have also spread our wings to be a trusted supplier of solar rooftops, solar street lights, solar pumps, solar integrated heat pumps, and water purification plants across India.

## NUETECH GLASS LINE SOLAR WATER HEATER

- 1 openable doors for cleaning the tank
- 2 Glass Lined Coating to avoid corrosion
- 3 High-Pressure High-Density PUF Insulation
- 4 Capsule Dish end shaped Tank Withstands greater pressure
- 5 Structure with 3 legs for more Strength & longer life
- 6 Gold standard tubes which gives maximum Hot water (e.g: 200 LPD 20 Tubes)

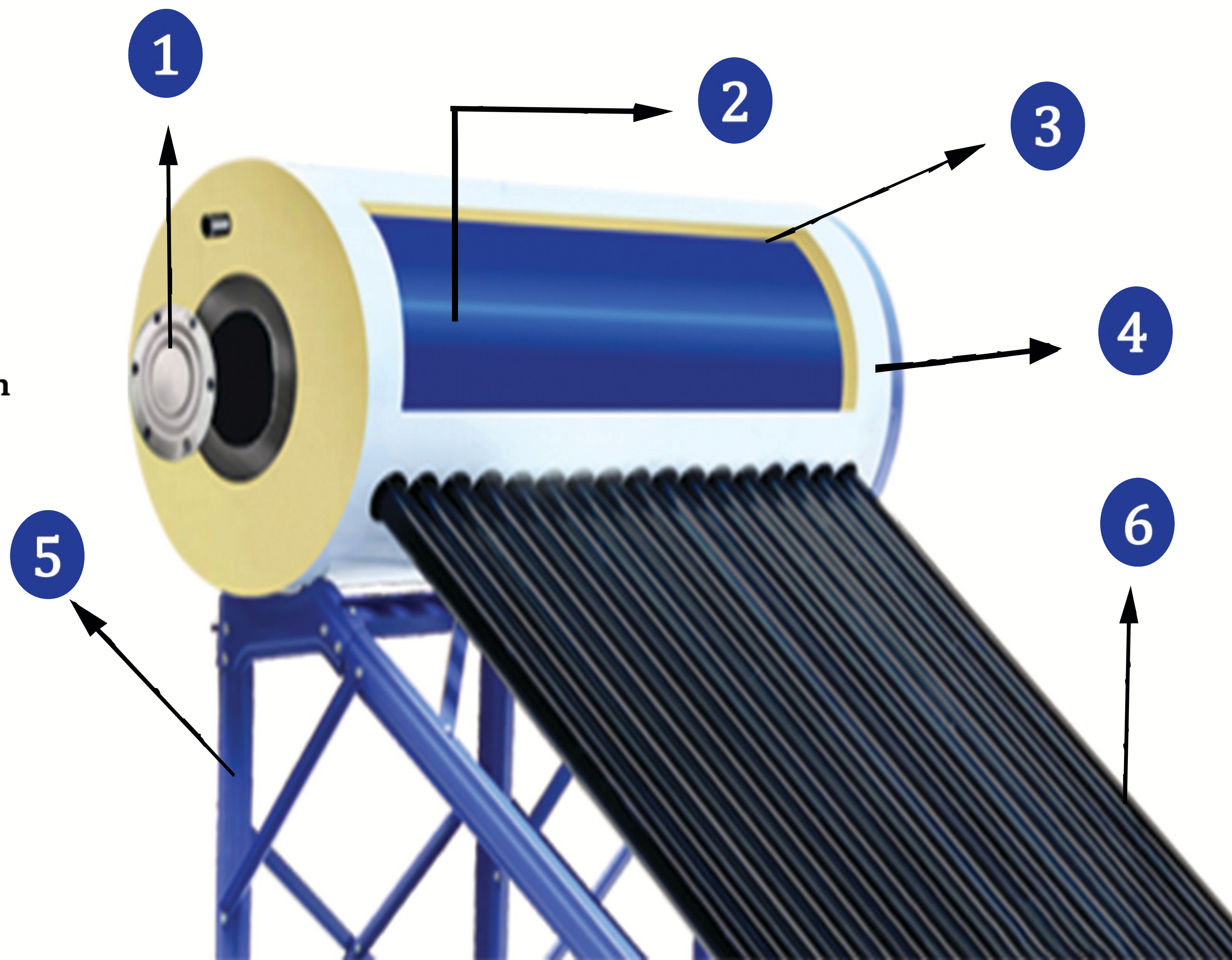

### TECHNICAL SPECIFICATIONS

Type of Collector	:	ETC
System Capacity (precisely)	:	120,170,220,320 & 500 LPD
Inner tank Materials	:	1.6 mm, low carbon TATA Steel
Inner tank Protection coating	:	Food grade Enamel Glass lined with 200 TO 250 Micron thickness.
Puff Density	:	40 Kg/Mt <sup>3</sup>
ETC Tubes	:	Ø 58 X 2100 mm, Boro silicate Glass tubes with 0.92 Absorbity
Puff Insulation	:	Polyurathene Foam, CFC FREE.
Special Feature	:	Digital controller with 24x7 Hot water.

## BENEFITS OF NUETECH GLASS LINE SOLAR WATER HEATER ( ISI MARKED, BIS APPROVED SOLAR WATER HEATERS)

- Uniform thickness of Glass line ensures the Hot water Remains hot for a long duration
- It is environmentally friendly, safe and suitable for all types of water.
- It prevents the accumulation of chemicals, salt and impurities on the surface of the water tank.
- Glass line ensures the tank stays free from corrosion & leakages.
- Special Profile Rolled Section Stand provides stability and strength to system
- Openable doors for cleaning the tank
- High Pressure High Density PUF Insulated storage tank to retain the Hot water for longer duration.
- More Gold standard tubes which gives Maximum hot water.
- Capsule Dish end- shaped Tank with stands greater pressure
- Lakhs of Satisfied Customers across India



### NORMAL SOLAR WATER HEATER VS GLASS LINE SOLAR WATER HEATER

Typically made of stainless steel or mild steel/ GI Tank

prone to corrosion over time, especially in areas with hard water or harsh environmental conditions

Heat retention may vary, and the efficiency can be affected by factors like temperature and insulation. Because of Low density insulation material and no cleaning provided for cleaning the tank

May require more regular maintenance, and the lifespan can be influenced by factors like water quality and maintenance practices and tank corrosion occurs rapidly.



Features a glass-lined tank, which is a layer of glass coating on the inner surface of the tank, enhancing durability and corrosion resistance.



Offers enhanced rust resistance due to the protective glass layer, extending the lifespan of the system.



The glass lining improves heat retention, ensuring that the water stays hot for a more extended period, even in less favorable weather conditions.



The German-made glass lining technology enhances durability, ensuring an extended lifespan and minimized wear and tear.

## OUR OTHER PRODUCTS



**Solar Roof Top**



**Solar Integrated Heat Pumps**



**Solar Street Lights**



**Dealers  
Across India**

**NUETECH SOLAR SYSTEMS PVT LTD.**

#5, NO 5 Shankarappa Industrail Estate, Magadi  
Main Rd, Sunkadakatte, Bengaluru, Karnataka 560091



+91 92431 44444



[www.nuetechsolar.com](http://www.nuetechsolar.com)

